



H5 Heat Controller

Controller for thyristor (SCR) contactor (AC switch).
Part No. 90-90-72

For s/w version 1.01

Advanced Resistance Welding Control Systems



Entron Controls

Phone: +1-864-416-0190

Email: tech.support@entroncontrols.com

- Welding controls.
- Thyristors and power supplies
- Power Inverters.
- Meters and Monitors.
- Training and Support.
- Consultancy.

Table of contents

Page

4. About the H5.
5. Configuration.
6. ..configuration
7. Inputs and outputs.
8. Connection diagram.
9. Analog control inputs.
10. Handshake signals.
11. Basic application.
12. Timed application.
13. Dual transformer application.
14. Tap change application.
15. Diagnostic indicators.
16. Specification.

About the H5

The H5 is a small accessory unit which can be used to control any pulse driven thyristor (SCR) contactor or AC switch. The H5 can be applied to any situation requiring control of an AC switch, such as resistance welding equipment, industrial process heating etc.

Features

- 0 to 10 V control inputs.
- Continuous or timed operation.
- Timer function 0...1 s / 0...10 s.
- Synchronous heat / tap change.
- 1st half-cycle delay for soft start.
- Handshake signals for automation.
- Thermal contact input.
- 50/60 Hz operation.
- Din-rail mounting.
- 2-part plug-in terminal block connectors.

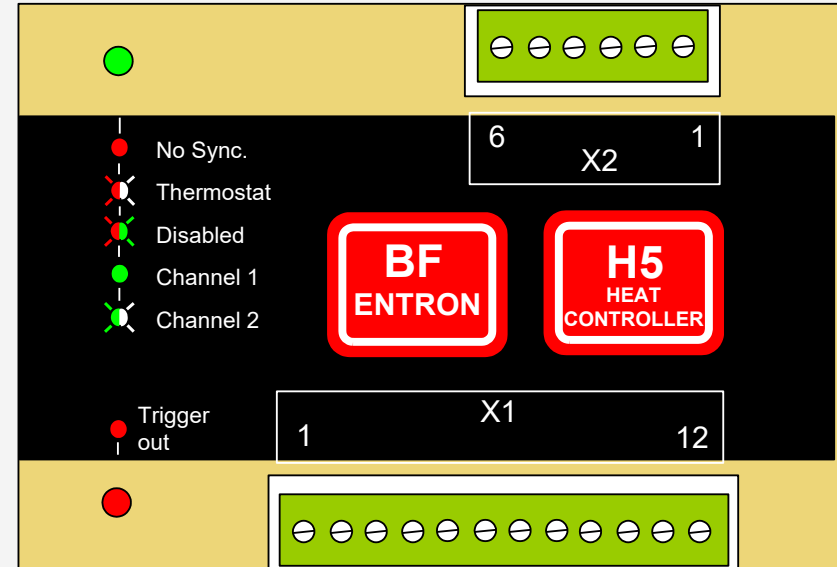

Configuration

The H5 is configured by inserting or removing jumpers on the pcb. To access the jumpers, remove the cover by slackening the two screws on each side (this is easiest to do before the unit is clipped onto the DIN rail). The jumpers can be seen at the top of the board and are labelled J2 to J7. In the picture below, J2 is inserted and J3 to J7 are removed.

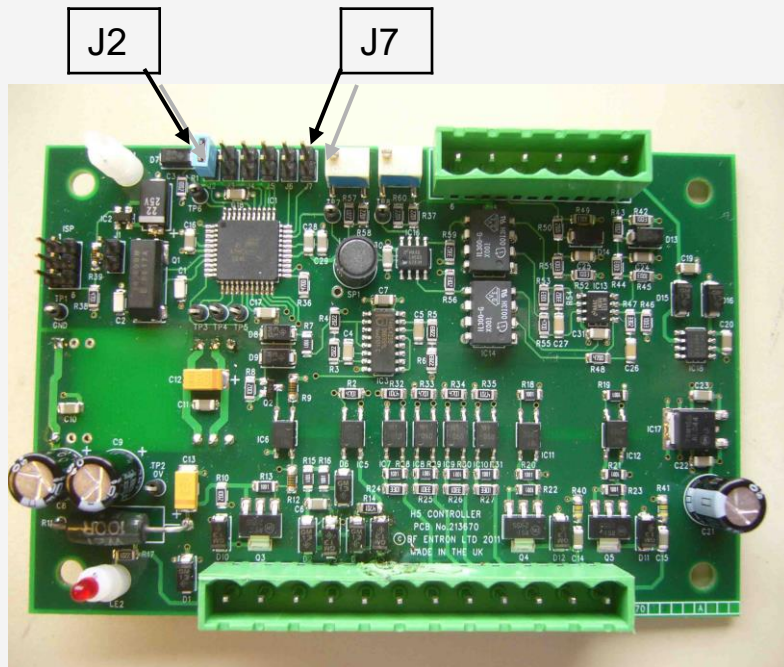

Jumper functions		
<u>Jumper</u>	<u>Inserted</u>	<u>Removed</u>
J2	Continuous	Timed
J3	60 Hz	50 Hz
J4	0..10 s	0..1 s
J5	No Cool time	1 cycle cool time
J6	-	-
J7	-	-

J6,7 are reserved and must NOT be inserted.

...configuration

Notes:

J2: selects *continuous* or *timed* operation. If *continuous* operation is configured, the trigger output will be active while the START input is on. If *timed* operation is configured, the trigger output will come on when the START input comes on, and will remain on until either the set time period ends or the START input goes off.

J3: selects *50 Hz* or *60 Hz* operation. Set this jumper to match the frequency of the mains supply in your area.

J4: selects the timing range as either *0...1 seconds* or *0..10 seconds*. The time is controlled via the input to channel 2. J4 has no effect if J2 is set to *continuous*.

J5: selects cool time to be inserted when switching channels.

J6,7: reserved (do NOT insert jumper).

Inputs and Outputs

<u>X1</u>	<u>In/Out</u>	<u>Function</u>
1	Input	+24V supply
2	Input	0V supply
3	Input	Synchronising signal, 27V AC
4	Input	
5	output	Trigger +
6	output	Trigger -
7	Input	START. On = 24V, Off = 0V
8	Input	Channel select. Off (0V)=Channel 1, On(24V) = Channel 2.
9	Input	ENABLE. On = 24V, Off = 0V (acts as a gate to the trigger output)
10	Input	Thermal contact monitor (n/c).
11	Output	Channel 1 active. On = 24V, Off = 0V
12	Output	Channel 2 active (continuous operation) / End of Sequence (timed operation). On = 24V, Off = 0V

<u>X2</u>	<u>In/Out</u>	<u>Function</u>
1	Output	+10V supply for control potentiometer
2	Input	Channel 1 control input 0..10V
3	Input	Channel 1 control input 0V
4	Output	+10V supply for control potentiometer
5	Input	Channel 2 control input 0..10V
6	Input	Channel 2 control input 0V

Connection diagram

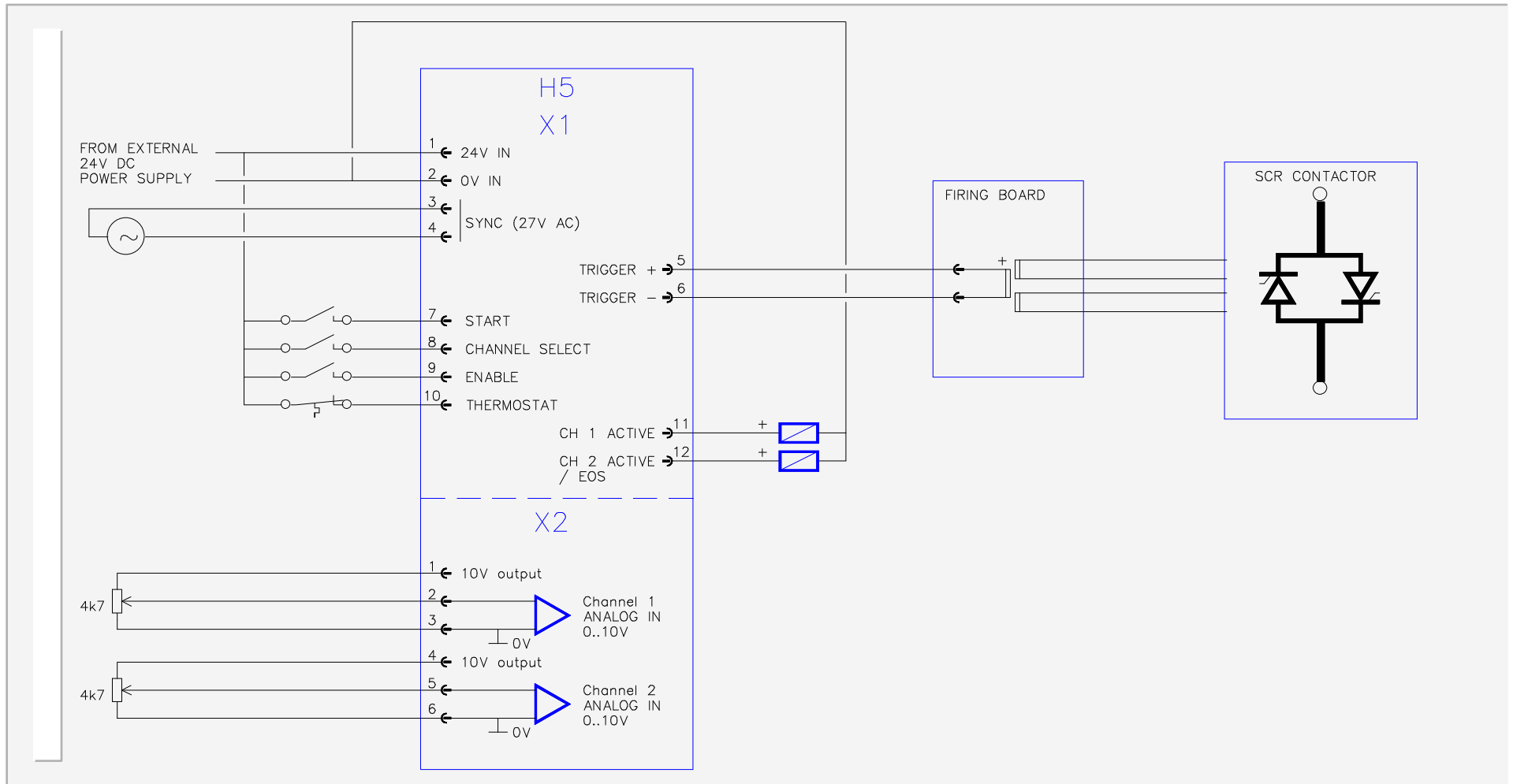

Analog control inputs

The two analog inputs on connector X2 can be driven by connecting a 4k7 potentiometer as shown in the connection diagram. Alternatively, they may be driven from an external 0 to 10V source.

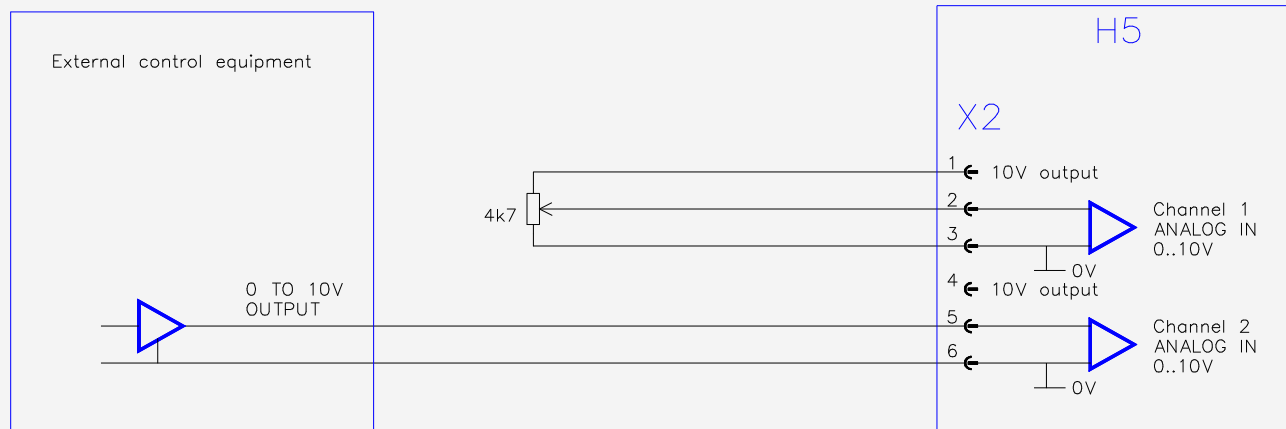

Note that the H5 analog inputs are referenced to 0V (X1 pin 2). If the external equipment requires an isolated connection, then the control signal should be connected to the H5 via a signal isolation amplifier. e.g. BF Entron ISOAMP, part no. 90-90-61

Handshake signals

The two discrete outputs on connector X1 can be used to signal back to external control equipment.

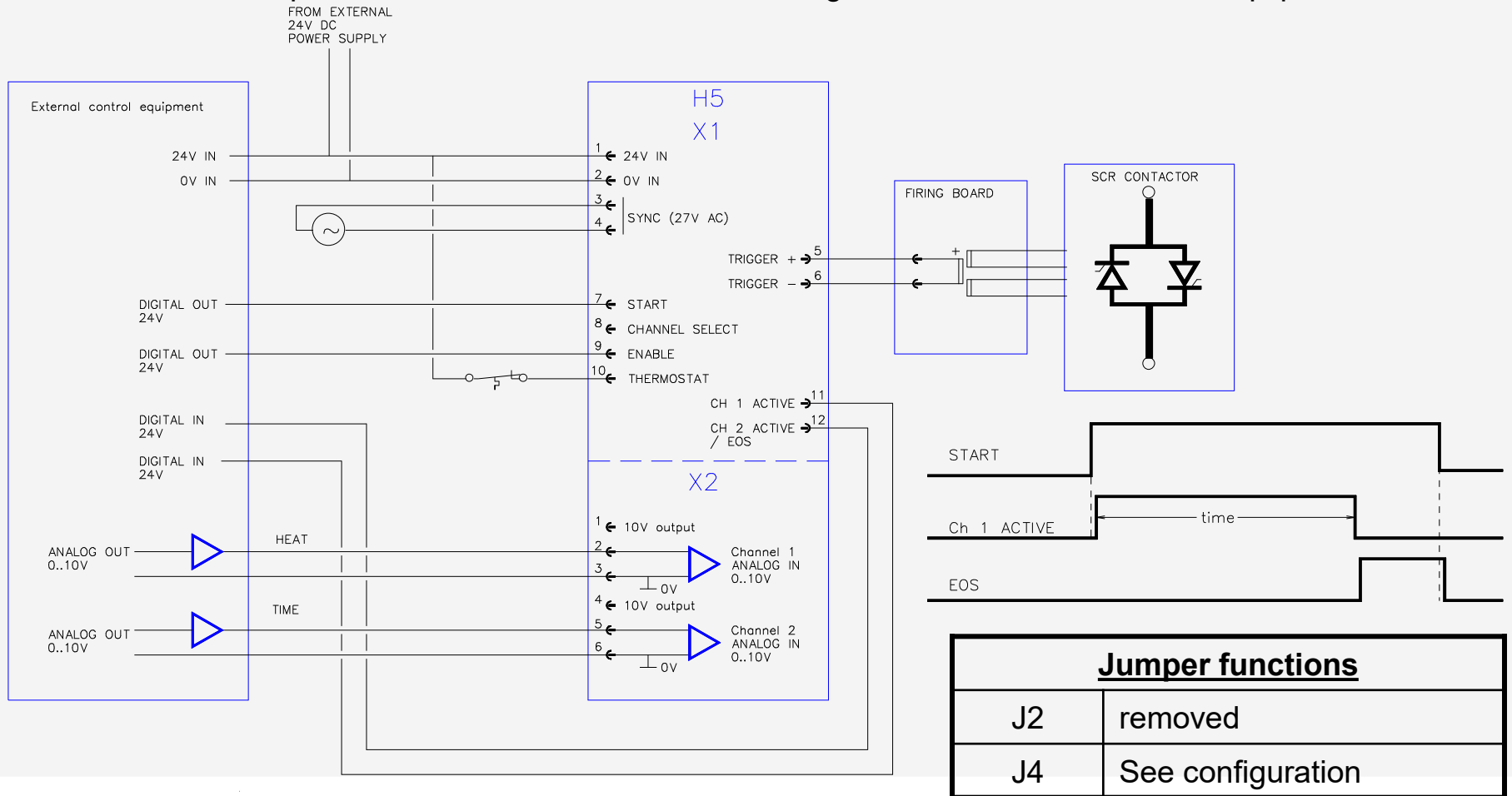

Basic application

This is the most basic application where a single input controls the heat, and the START input controls the time.

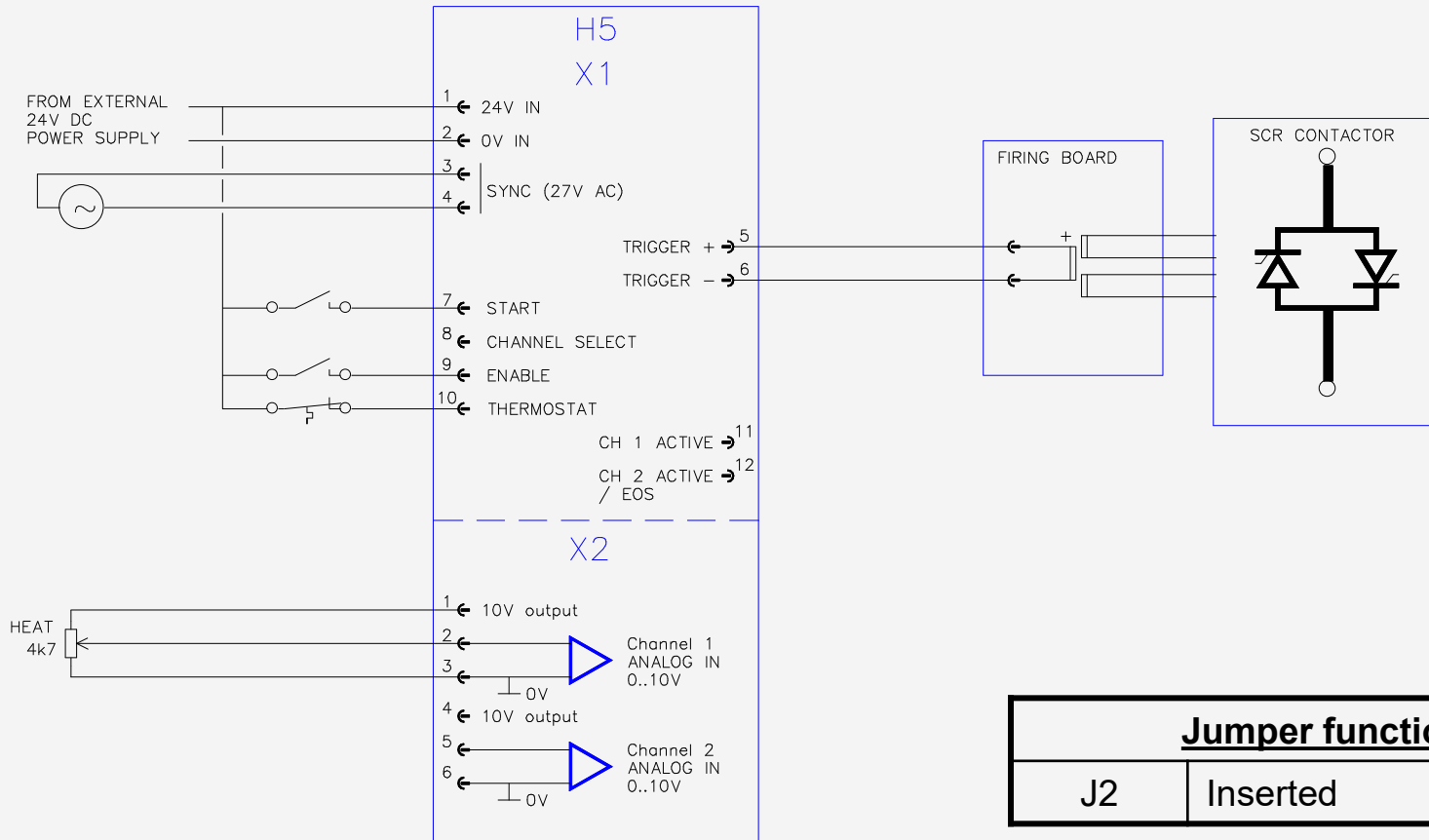

Timed application

In this application, one input controls the heat, and the other input controls the time.

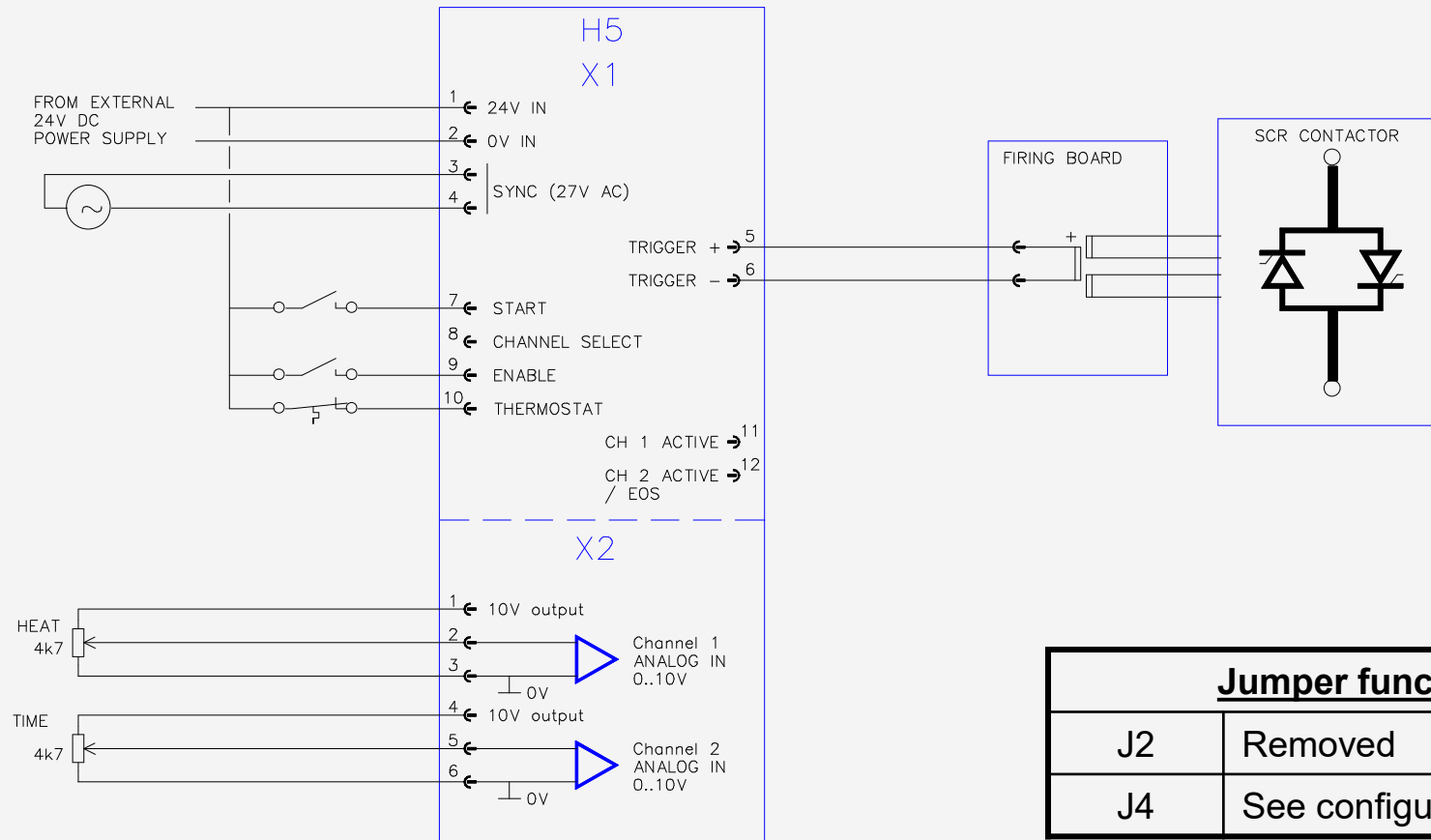

Dual transformer application

In this application, two transformers can be driven, each with its own heat control. The START input controls the time.

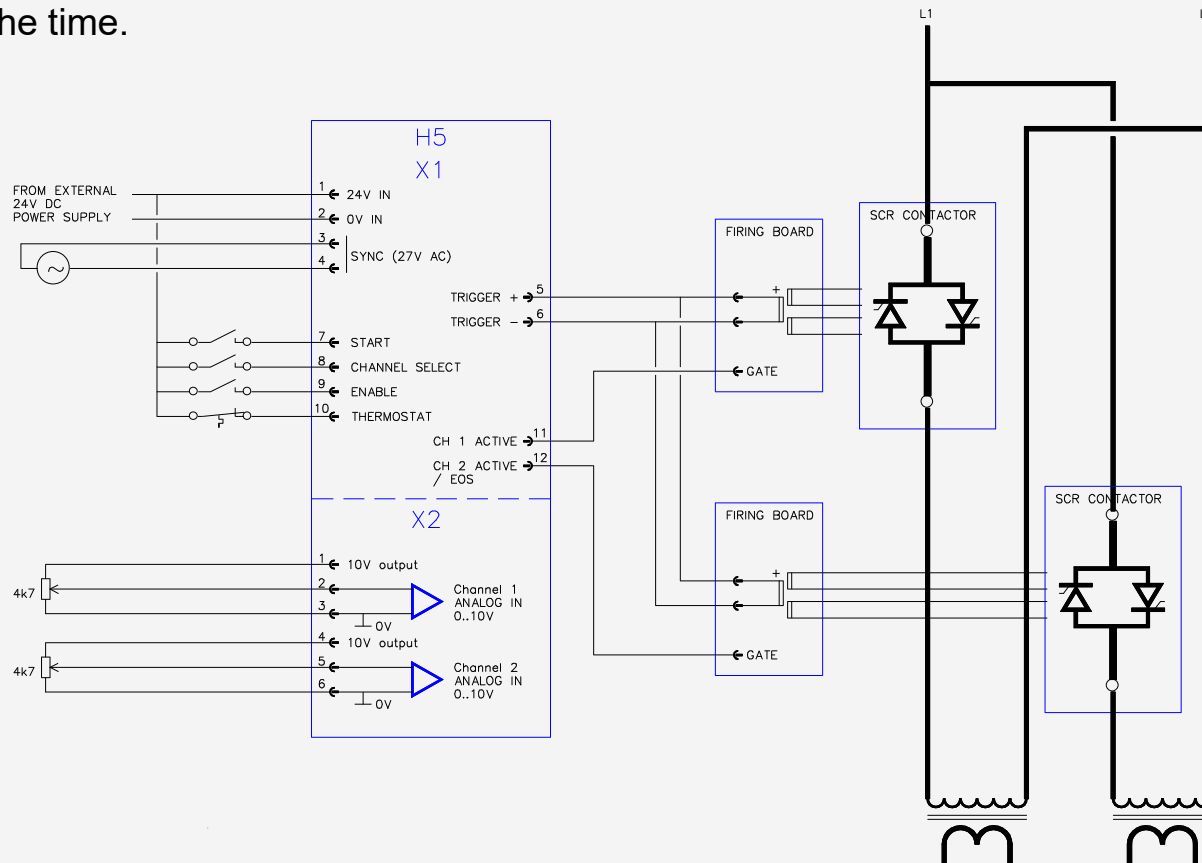

Note that special firing cards having a GATE input are required.

e.g. Entron WSG card, part no. W293233.

Jumper functions

J2	Inserted
----	----------

Tap change application

In this application, the H5 acts as an automatic tap change switch. Each tap has its own heat control. The START input controls the time.

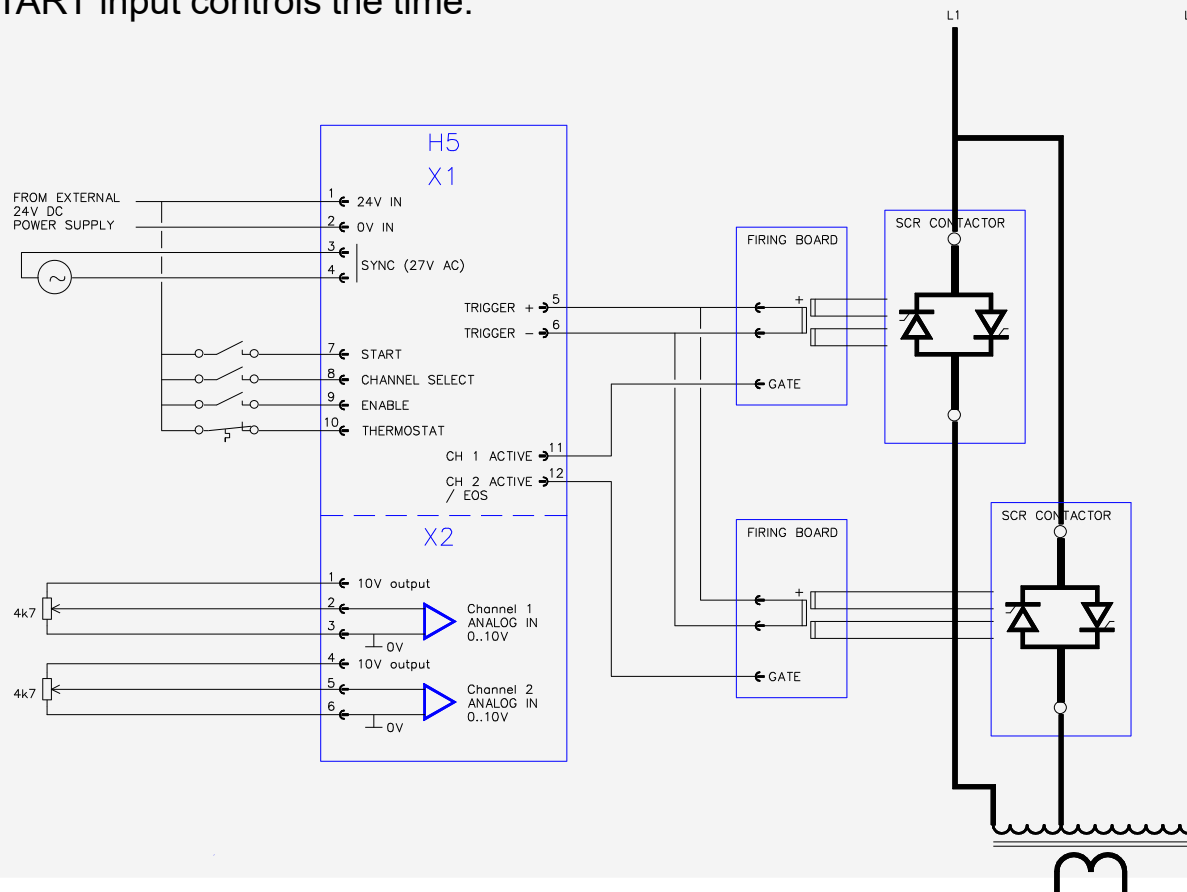

Note that special firing cards having a GATE input are required.

e.g. Entron WSG card, part no. W293233.

Jumper functions

J2	Inserted
J5	Insert for NO cool time

Diagnostic indicators.

There are two diagnostic indicators on the top of the unit:

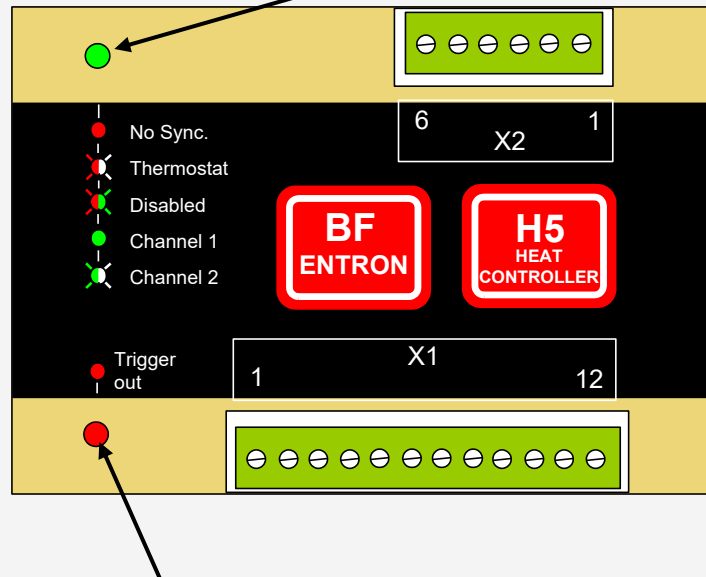

<u>STATUS LED colour</u>	<u>Condition</u>
Off (white)	Idle
Solid green	Running (channel 1)
Flashing green	Running (channel 2)
Solid red	Synchronising error
Flashing red	Thermal input is off
Flashing red/green	ENABLE input is off

Trigger out: This will light (red) when the trigger output is active.

Specification

Width	125 mm
Height	83 mm
Depth (above DIN rail)	43 mm (including connectors)
Weight	420 g
Power requirements	24 V DC (+/-10%), 0.4 A
Synchronising signal	27 V AC (+/-10%), 1 VA.
Synchronising frequency	50 or 60 Hz (+5/-10 Hz)
Inputs (discrete)	24 V DC (+/-10%), 10 mA max.
Outputs (discrete)	24 V DC (as supply), 100 mA max.
Inputs (analog)	0 to 10 V. Input impedance >100k
Reference output	10 V, 10 mA max.
Trigger output	5 kHz, 1:10 ratio.